

F

E

D

C

B

A

RoHS
Compliant

SYMBOL

REVISION

APPROVAL

DATE

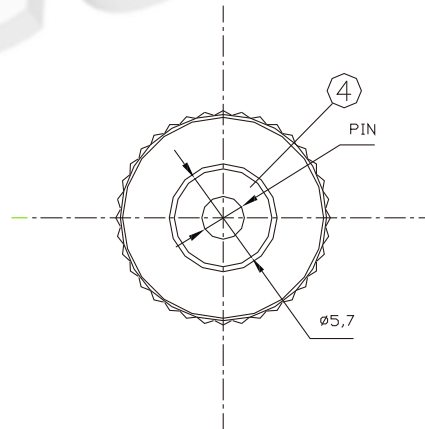
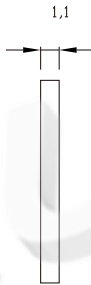
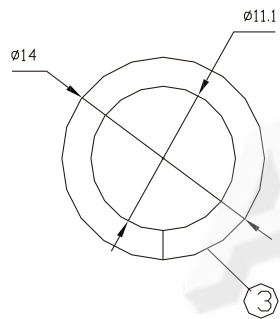
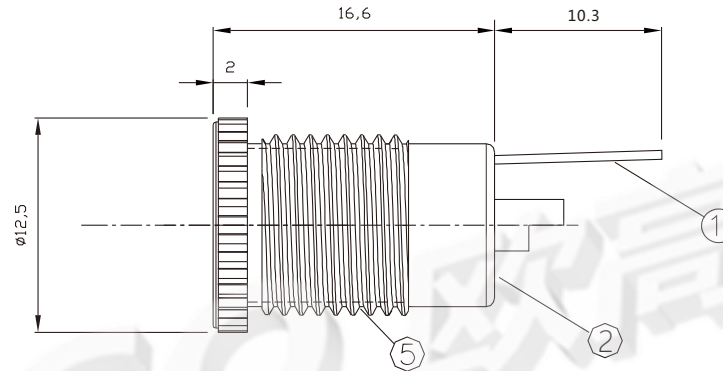
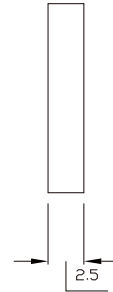
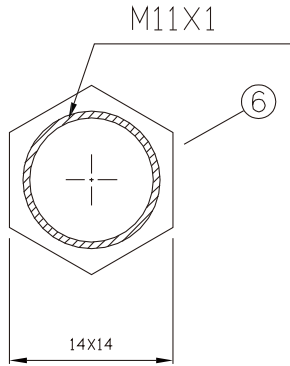

PIN	$\phi 1.65$	$\phi 2.0$	$\phi 2.5$
APPO			

主要技术性能	公差	
额定电负荷	DC 30V\3.0A	X.±0.20
接触电阻	≤0.03Ω	. X±0.10
绝缘电阻	≥100MΩ	. XX±0.05
耐压	AC500V(50Hz)/min	. XXX±0.02
插拔力	3-20N	. X'±5°
使用温度范围	-30-70°C	. X"±2°
使用寿命	5000次	. XX'±1°

序号	产品名称	数量	材料	规格	电镀
6	螺帽	1	H62黄铜棒	T=2.50	镀镍
5	铜套	1	H62黄铜棒		镀镍
4	中心针	1	H62黄铜棒		铜锡
3	垫片	1	锰钢带	T=1.10	铜锡
2	底座	1	PPA	黑色	
1	弹片	1	H65磷铜带	T=0.35	铜锡

DONGGUAN AUGO ELECTRONICS CO.,LTD.

COPYRIGHT RESERVED,PLEASE DO NOT COPY.

PART NAME		DC POWER JACK			DRAWING		G.C.Chen		DWG.No.		
PART NO.		DS-198			CHECK		G.C.Chen		REV. A		
UNIT :		TOLERANCE		UP TO 5		APPROVAL		DATE			
mm		OTHERWISE		ABOVE 5	±0.2	SCALE		PAGE		1 OF 1	
				ABOVE 30	±0.3	3:1		DATE			
				ANGLE	±0.5			REV.			
				ANGLE	±3'			DATE			
					0'±3'			PAGE			

F

E

D

C

B

A