

ST-055S-D1-4

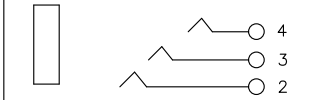

ST-055S-D1-3

CIRCUIT

RoHS Compliant

SYMBOL	REV.	REVISION	APPROVAL	DATE

SPECIFICATIONS

- ELECTRICAL CHARACTERISTICS:
 - 1-1.RATING: DC 12V 1A
 - 1-2.CONTACT RESISTANCE: 30mΩ MAX(INITAL)
 - 1-3.DIELECTRIC WITHSTANDING VOL TAGE: 500V AC FOR ONE MINUTE
 - 1-4.INSULATION RESISTANCE: 100MΩ MIN,MEASURED BY 500V DC
- MECHANICAL CHARACTERISTICS:
 - 2-1.INSERTION FORCE: 0.3-3.0KG
 - 2-2.WITHDRAWAL FORCE: 0.3KG-3.0KG
- LIFE TEST:5,000 CYCLES MIN

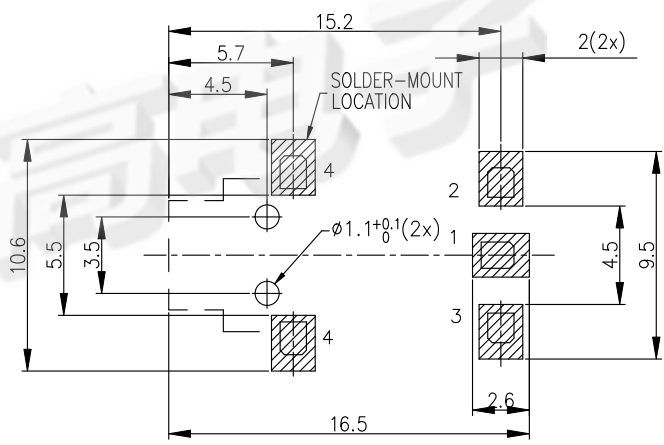
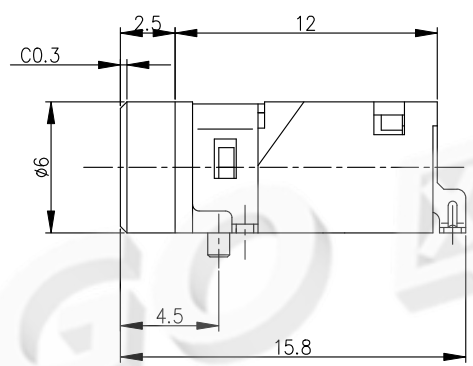
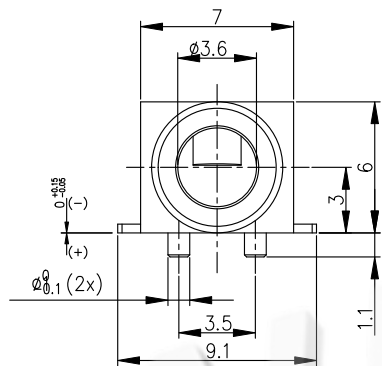

P.C.B LAYOUT TOP VIEW

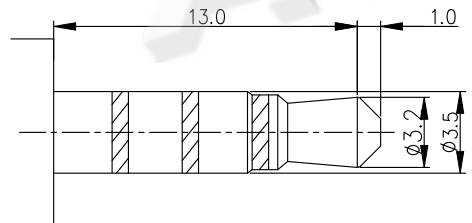

MATING PLUG

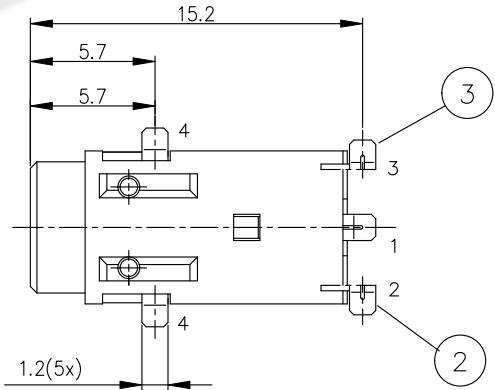

No.	DESCRIPTION	MATERIAL	PLATING
1	TERMINAL ①	C5210	Ag PLATED
2	TERMINAL ②	C5210	Ag PLATED
3	TERMINAL ③	C5210	Ag PLATED
4	TERMINAL ④	C5210	Ag PLATED
5	HOUSING	PPA	BLACK

DONGGUAN AUGO ELECTRONICS CO.,LTD.

COPYRIGHT RESERVED, PLEASE DO NOT COPY.

PART NAME		PHONE JACK(SMD)		DRAWING	G. C. Chen	DWG. No.	
PART NO.		PJ-055S-D1-4-TR		CHECK	G. C. Chen	REV.	A
UNIT :	TOLERANCE UNLESS	X. X ± 0.3	ANGLE	APPROVAL		DATE	2017/08/04
	mm	X. XX ± 0.2		SCALE	1:1	PAGE	1 OF 1
	OTHERWISE SPECIFIED	X. XXX ± 0.1	±2°				