

Rohs

REV.	DESCRIPTION	DRAW.	DATE.

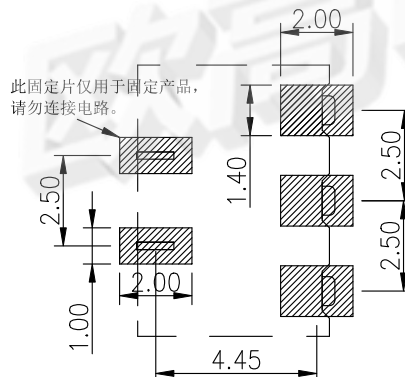
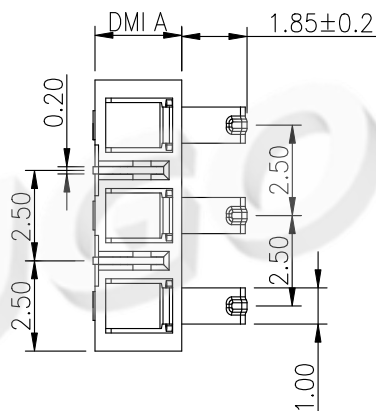
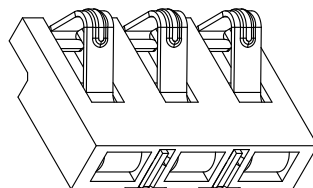
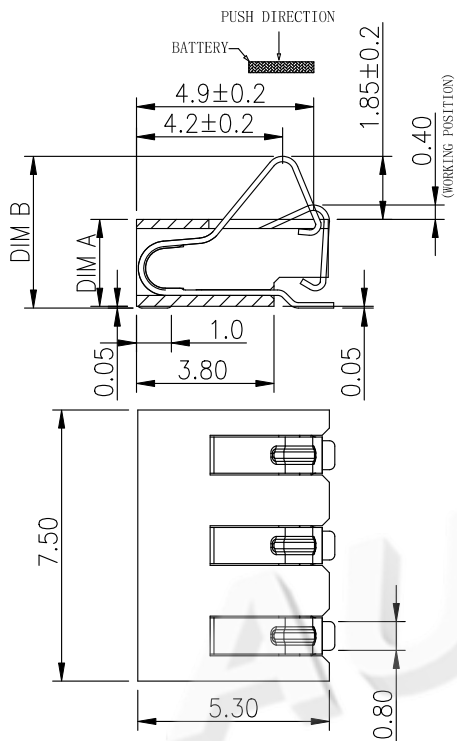

RECOMMENDED PCB LAYOUT  
TOP VIEW (. XX ± 0.05)

PART NO.	DIM A	DIM B
AUGO-BC-25-3P430	2.4	4.30 ± 0.2
AUGO-BC-25-3P490	3.0	4.90 ± 0.2
AUGO-BC-25-3P540	3.5	5.40 ± 0.2

Material:  
 Insulator : LCP(UL94V-0)  
 Contact : Phosphor Bronze  
 Contact Plated : Gold over Nickel or Tin  
 Specification:  
 Current Rating : 2A  
 Voltage Rating : 12V  
 Contact Resistance : 50m Ω  
 Insulation Resistance : 500M Ω  
 Dielectric Voltage : 500V  
 Operating Temperature : -40°~85°  
 Electrical Life : 5000cycles

**AUGO**

AUGO ELECTRONICS CO.,LTD.

COPYRIGHT RESERVED, PLEASE DO NOT COPY.

REV:	01	UNLESS OTHERWISE SPECIFIED, TOLERANCE:	TITLE:	2.5 PITCH BATTERY CONNECTOR	DESIGN	G.C.CHEN	DATE	
SIZE:	A4				X.	±0.20	DRAWING	Y.C.ZHANG
SCALE: 1:1	UNIT: mm	X.x	±0.15	PART NO:	CHECK	D.J.WANG	DATE	
SHEET: 1/1		X.xx	±0.10		AUGO-BC-25-3PD	SCALE	1:1	PAGE
		ANGULAR	±2°					